

Bergmann Dumper 3012 Three-way-tip

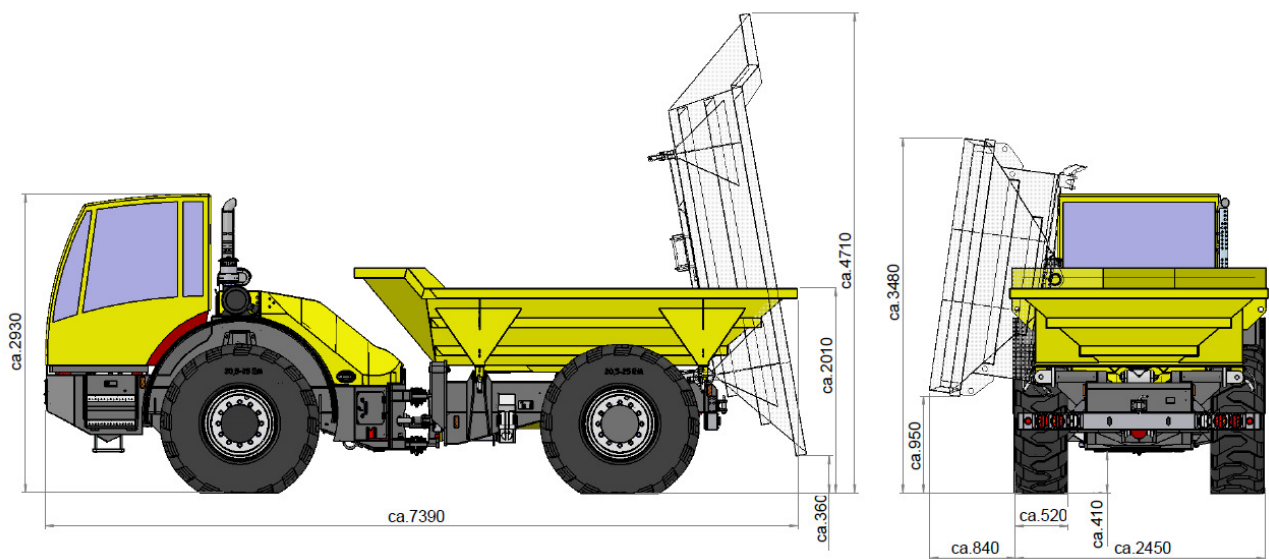

Strong arguments for your advantage

- ▶ high stability thanks to oscillating axle
- ▶ swivelling operator's stand
- ▶ electro hydraulic spring type cylinder park brake
- ▶ compact dimensions with low weight





Bergmann Dumper

3012 Three-way-tip

Technical Data

Weight / Bucket capacity	Payload	12.000 kg																			
	Unladen weight	10.020 kg																			
	Bucket capacity struck	4.400 l																			
	Bucket capacity heaped	7,5 m ³																			
	Bucket system	Hydraulical 3-way-tipper, change of sides by simply changing the socket pins																			
Dimensions	Height with cabine	2.960 mm																			
	Total length	7.380 mm																			
	Total width	2.500 mm																			
	Ground clearance	400 mm																			
Transmission	Load-depending shift – manually shiftably by hand and automatically, self-adjusting optimisation of traction force and speed, speed control stepless forward and backwards, ZF-Ergo-Power transmission																				
	<table border="1"> <tr> <td>1. gear F</td> <td>- 5 km/h</td> <td>2. gear F</td> <td>- 9 km/h</td> </tr> <tr> <td>3. gear F</td> <td>- 14 km/h</td> <td>4. gear F</td> <td>- 21 km/h</td> </tr> <tr> <td>5. gear F</td> <td>- 32 km/h</td> <td>6. gear F</td> <td>- 40 km/h</td> </tr> <tr> <td>1. gear R</td> <td>- 6 km/h</td> <td>2. gear R</td> <td>- 14 km/h</td> </tr> <tr> <td>3. gear R</td> <td>- 34 km/h</td> <td></td> <td></td> </tr> </table>	1. gear F	- 5 km/h	2. gear F	- 9 km/h	3. gear F	- 14 km/h	4. gear F	- 21 km/h	5. gear F	- 32 km/h	6. gear F	- 40 km/h	1. gear R	- 6 km/h	2. gear R	- 14 km/h	3. gear R	- 34 km/h		
1. gear F	- 5 km/h	2. gear F	- 9 km/h																		
3. gear F	- 14 km/h	4. gear F	- 21 km/h																		
5. gear F	- 32 km/h	6. gear F	- 40 km/h																		
1. gear R	- 6 km/h	2. gear R	- 14 km/h																		
3. gear R	- 34 km/h																				
Steering	Hydraulical articulated steering acting over priority valve articulation: 37° left & right																				
Axles / brakes	Front axle hydraulically shock absorbed, rear axle fix, maintenance-free-oil-bath multi-disc brake in the wheel hubs with self-locking differential with a locking value of 45 %, hydraulically applicated spring-type cylinder locking brake acting over articulated shaft on front and rear axle.																				
Engine	4-cylinder Cummins Diesel engine –water cooled- stage 3B/Tier 4 Interim power 119 KW with 2.200 rpm																				
Tyres	Standard 20.5 R 25 double coin																				
Bonnet	Easy access to all maintenance and service points thanks to wide opening sectioned bonnet																				
Tank capacity	Fuel 190 L Hydraulic oil 64 L																				
Electrics	24 V electric system with main switch, fault finding modus, fuel and hour counter, control lamps for engine oil, parking brake, driving direction display, battery charging control, hydraulic filter, display for drive position																				
Standard equipment	Comfortable driver's cab with air-suspended driver's seat, swivelling operator's stand, lighting system according to German traffic regulations, bucket from abrasion proof fine grain steel, flashing yellow light, cigarette lighter, roller blind for front windscreen, device for radio, loudspeaker and antenna EC declaration of conformity																				